

# Rondo Drinking Fountain



The Veitch Rondo drinking fountain is a round, freestanding, single station, non-refrigerated drinking fountain particularly suited for use in schools, recreation centres and public spaces. It comes complete with a sturdy vandal-resistant bubbler.

Veitch stainless steel drinking fountains are sold throughout Australia exclusively through the building & plumbing merchants.

## Technical Data

<b>Product</b>	Rondo Drinking Fountain	
<b>Type</b>	Free Standing & Non Refrigerated	
<b>Suitable For</b>	Internal/External Use	
<b>Material</b>	Gr304 Stainless Steel	
<b>Material Thickness</b>	1.2mm	
<b>Material Surface Finish</b>	Satin Finished	
<b>Mounting</b>	Mounted to concrete pad using punched holes in base.	
	Access to base and plumbing connections is through a secured panel.	
<b>Bubbler</b>	Chrome plated with Rubber Mouth Guard	
	Max. water Pressure is 350KPa	
	Inlet: 3/8 BSP	
<b>Outlet Size</b>	DN40 (38 BSP)	
<b>Overall height</b>	725mm	Item No. 04-2197
	900mm (Made to Order)	Item No. 04-2210
<b>Overall Diameter</b>	370mm	
<b>Overall Bowl Depth</b>	67mm	

The information in this sheet reflects the current technical specifications at the time of publication. As part of our continuous improvement program, we reserve the right to change the technical or physical specifications without notice.

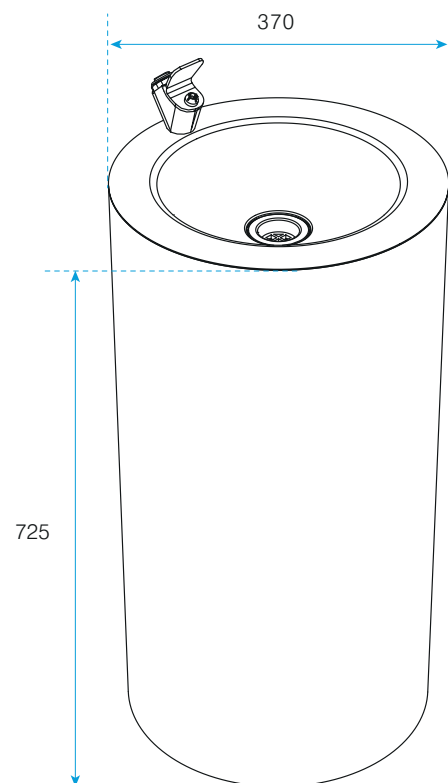



# Rondo Drinking Fountain

